

---

**Single Channel Bare-Bone USB Switch****■ FEATURES**

- 170m $\Omega$  High-Side MOSFET Switch.
- 1A Continuous Load Current.
- 40 $\mu$ A Quiescent Supply Current.
- 3.2V to 5.5V Input Voltage Range.
- Under-Voltage Lockout.
- Current-Limit / Short Circuit Protection.
- Thermal Shutdown Protection under Over Current Condition.
- Under Voltage Lockout Ensures that Switch is off at Start Up.
- Soft Start prevents large Inrush Current.
- No Reverse Current when Power off.
- Available in SOT23-5 Packages.

**■ DESCRIPTION**

The AIC6194 is an integrated 170m $\Omega$  high-side power switch, the preferred circuit protection method for computer, consumer, multimedia and portable applications. AIC6194 can protect sensitive electronics from damage caused by both overcurrent and overtemperature events.

The protection includes current limiting with foldback, short circuit, soft start and thermal shutdown under overcurrent occurs.

Guaranteed minimum output rise time limits inrush current during hot plug-in as well as minimizing EMI and prevents the voltage at upstream port from dropping excessively.

**■ APPLICATIONS**

- USB Power Management
- High-Side Power Protection Switch
- Hot Plug-In Power Supplies
- Battery-Charger Circuits
- Portable Application.
- Digital televisions
- Computer
- Multimedia
- Mobile Phones

■ TYPICAL APPLICATION CIRCUIT

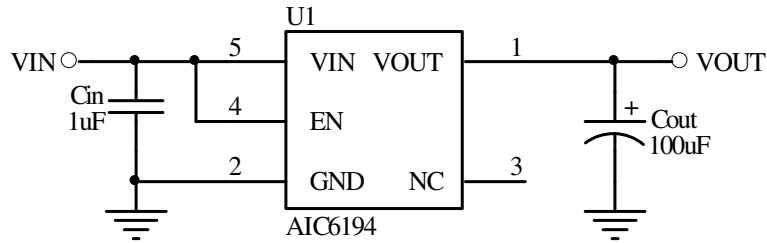

Typical Application Circuit

■ ORDERING INFORMATION

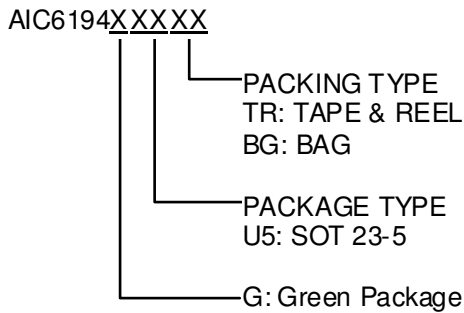

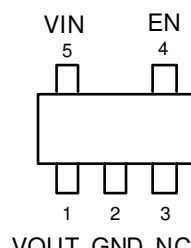
Package Type	Configuration
U5 (SOT23-5)	<p>TOP VIEW</p> 

Example: AIC6194GU5TR  
 → In SOT23-5 Green package and TAPE & REEL packing.

● Marking

Part No.	Package Code	Package Type	Marking
AIC6194	GU5	SOT23-5	6194G

**■ ABSOLUTE MAXIMUM RATINGS**

Supply Voltage ( $V_{IN}$ ).....	6.0V
Operating Temperature Range.....	-40°C~85°C
Junction Temperature.....	125°C
Storage Temperature Range.....	-65°C ~ 150°C
Lead Temperature (Soldering, 10sec) .....	260°C
Thermal Resistance, $\theta_{JC}$ (Junction to Case)     SOT23-5.....	115°C/W
Thermal Resistance, $\theta_{JA}$ (Junction to Ambient)     SOT23-5.....	250°C/W

(Assume no Ambient Airflow, no Heatsink)

**Absolute Maximum Ratings are those values beyond which the life of a device may be impaired.**

**■ ELECTRICAL CHARACTERISTICS**

( $V_{IN}=5V$ ,  $C_{IN}=1\ \mu F$ ,  $C_{OUT}=100\ \mu F$  (Note 2),  $T_A=25^\circ C$ , unless otherwise specified.) (Note 1)

PARAMETERS	CONDITIONS	MIN.	TYP.	MAX.	UNIT
Input Voltage		3.2		5.5	V
Supply Current			40		$\mu A$
Current Limit Threshold		1.05	1.45	1.80	A
Output MOSFET Resistance			170		$m\Omega$
Output Turn-On Rise Time	$R_L = 10\Omega$ each Output		300		$\mu S$
Output Turn-Off Fall Time	$R_L = 10\Omega$ each Output		0.7	20	$\mu S$
Soft Start Time			2		mS
Over Temperature Shutdown Threshold	$T_J$ Increasing $T_J$ Decreasing		145 125		$^\circ C$
Under Voltage Lockout			2.5		V
Under Voltage Lockout Hysteresis			200		mV

Note1: Specifications are production tested at  $T_A=25^\circ C$ . Specifications over the  $-40^\circ C$  to  $85^\circ C$  operating temperature range are assured by design, characterization and correlation with Statistical Quality Controls (SQC).

Note2: Electrolytic Capacitor is recommended for  $C_{OUT}$  capacitor.

**TYPICAL PERFORMANCE CHARACTERISTICS**

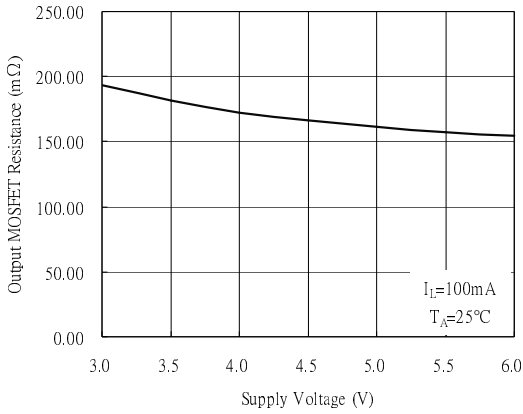

Fig. 1 Output MOSFET Resistance vs. Supply Voltage

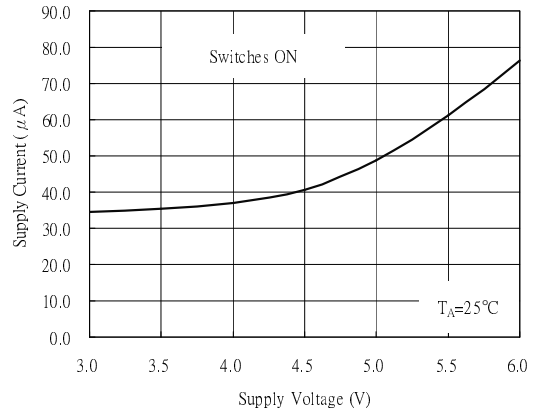

Fig. 2 Supply Current vs. Supply Voltage

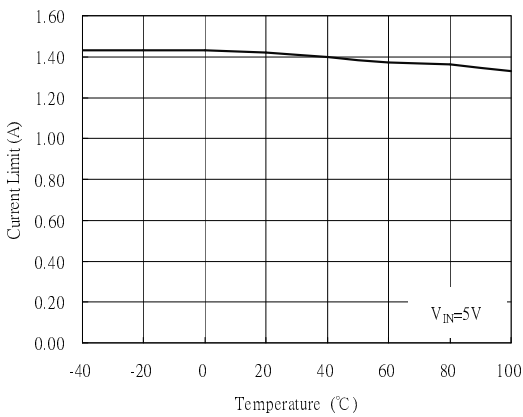

Fig. 3 Current Limit vs. Temperature

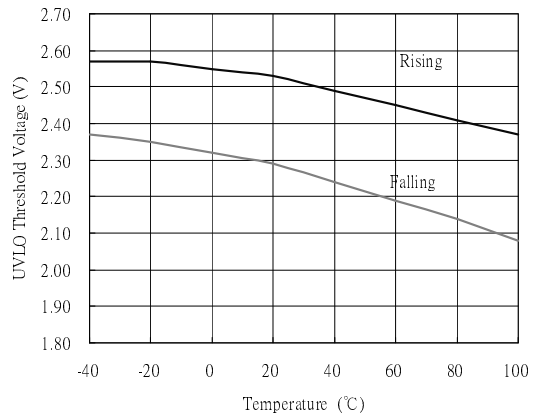

Fig. 4 UVLO Threshold Voltage vs. Temperature

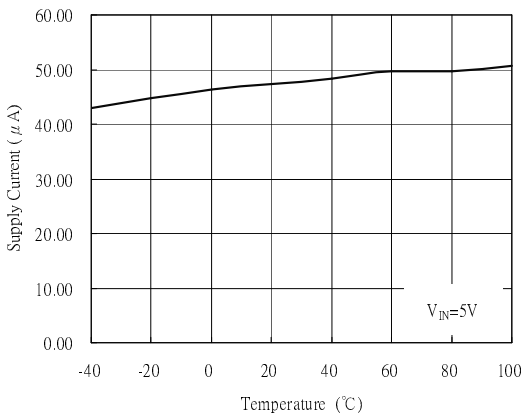

Fig. 5 Supply Current(μA) vs. Temperature

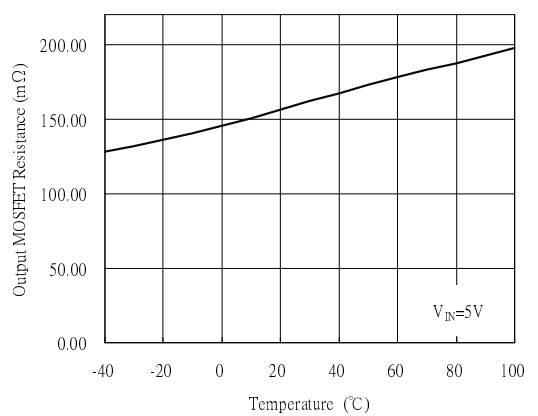
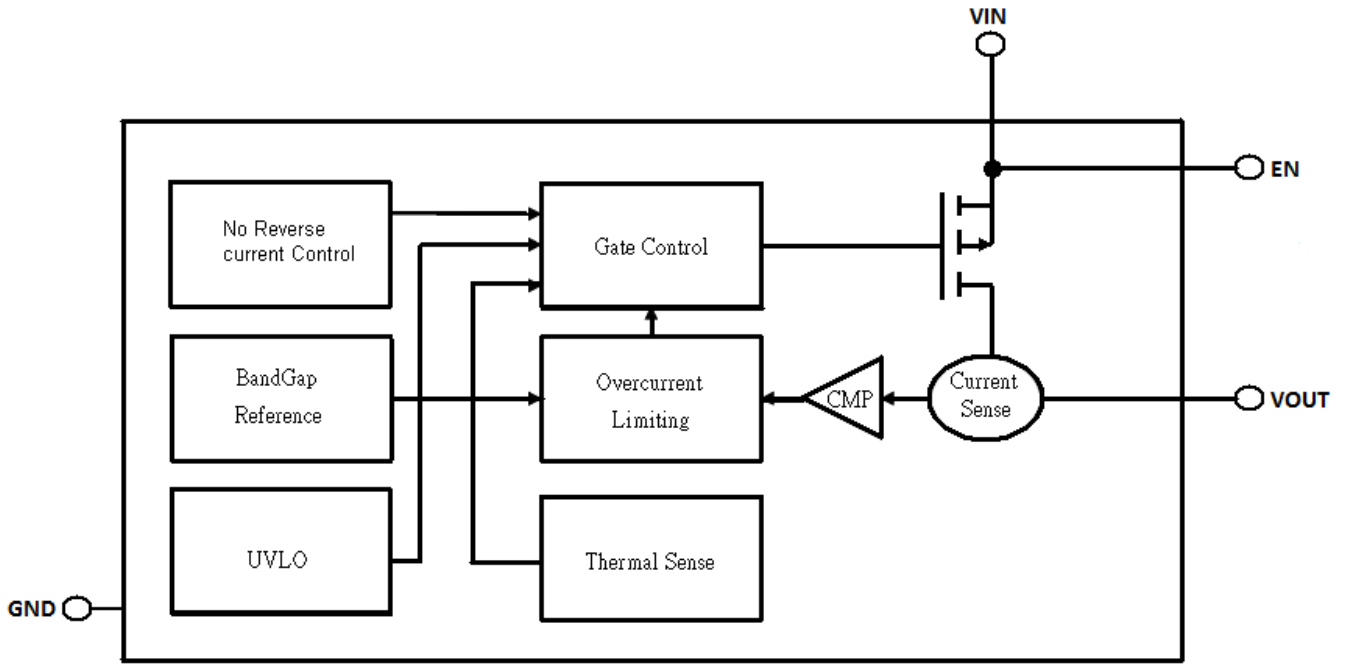

Fig. 6 Output MOSFET Resistance vs. Temperature

**■ BLOCK DIAGRAM**



Functional Block Diagram of AIC6194

**■ PIN DESCRIPTIONS**

Pin No.	Pin Name	Pin Function
1	VOUT	MOSFET switch output.
2	GND	Chip power ground.
3	NC	No connection.
4	EN	This pin always tie to high internally
5	VIN	Power supply input.

## ■ APPLICATION INFORMATION

### ● Current Limit

Current limiting is invoked when the load exceeds the set over-current threshold. It protects the output MOSFET switches from damage resulting from undesirable short circuit conditions or excess inrush current, which is often encountered during hot plug-in.

### ● Thermal Shutdown

When junction temperature of AIC6194 exceeds 145°C for any reasons, the thermal shutdown function turns MOSFET switch off. A hysteresis of 20°C prevents the MOSFETs from turning back on until the chip temperature drops below 125°C. thermal shutdown circuit functions only when the switch is enabled.

### ● Under-voltage Lockout

UVLO prevents the MOSFET switch from turning on until input voltage exceeds 2.5V typically. After the switch turns on, if input voltage drops below 2.3V typically, UVLO shuts off the output MOSFET.

### ● Supply Filtering

A 0.1μF to 1μF bypass capacitor from IN to GND, located near the device, is strongly recommended to control supply transients. Without a bypass capacitor, an output short may cause sufficient ringing on the input (from supply lead inductance) to damage internal control circuitry. Input transients must not exceed the maximum  $V_{IN}$  voltage for a short duration.

### ● Transient Requirements

USB supports dynamic attachment (hot plug-in) of peripherals. A current surge is caused by the input capacitance of downstream device. Ferrite beads

are recommended in series with all power and ground connector pins. Ferrite beads reduce EMI and limit the inrush current during hot-attachment by filtering high-frequency signals.

### ● Printed Circuit Layout

The power circuitry of USB printed circuit boards requires a customized layout to maximize thermal dissipation and to minimize voltage drop and EMI

**PHYSICAL DIMENSIONS**

- SOT23-5

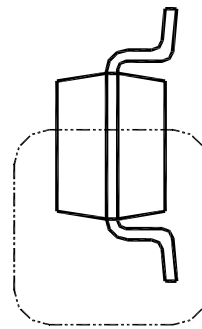
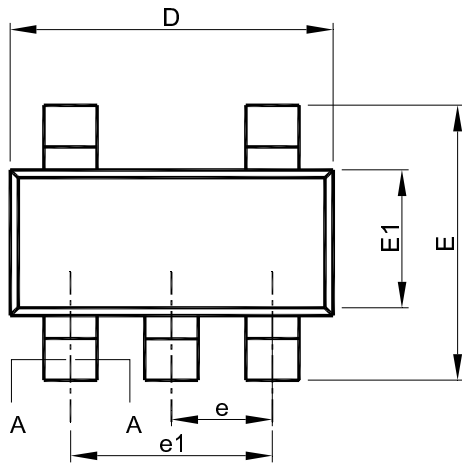

SEE VIEW B

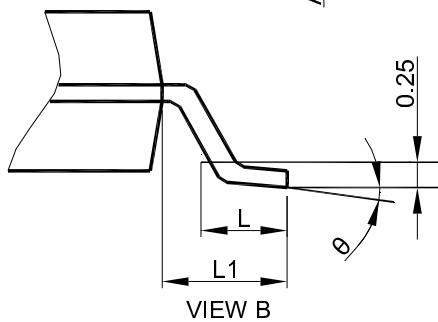
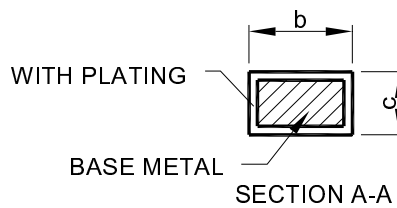
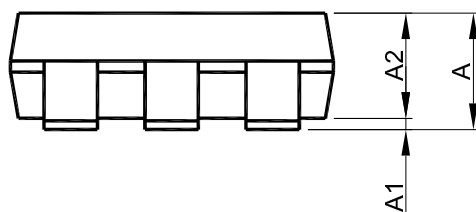

GAUGE PLANE  
SEATING PLANE

VIEW B

- Note :
1. Refer to JEDEC MO-178AA.
  2. Dimension "D" does not include mold flash, protrusions or gate burrs. Mold flash, protrusion or gate burrs shall not exceed 10 mil per side.
  3. Dimension "E1" does not include inter-lead flash or protrusions.
  4. Controlling dimension is millimeter, converted inch dimensions are not necessarily exact.

SYMBOL	SOT23-5	
	MILLIMETERS	
	MIN.	MAX.
A	0.95	1.45
A1	0.00	0.15
A2	0.90	1.30
b	0.30	0.50
c	0.08	0.22
D	2.80	3.00
E	2.60	3.00
E1	1.50	1.70
e	0.95 BSC	
e1	1.90 BSC	
L	0.30	0.60
L1	0.60 REF	
θ	0°	8°

**Note:**

Information provided by AIC is believed to be accurate and reliable. However, we cannot assume responsibility for use of any circuitry other than circuitry entirely embodied in an AIC product; nor for any infringement of patents or other rights of third parties that may result from its use. We reserve the right to change the circuitry and specifications without notice.

Life Support Policy: AIC does not authorize any AIC product for use in life support devices and/or systems. Life support devices or systems are devices or systems which, (i) are intended for surgical implant into the body or (ii) support or sustain life, and whose failure to perform, when properly used in accordance with instructions for use provided in the labeling, can be reasonably expected to result in a significant injury to the user.