

30V, 3A Wide-Input Range Step-Down Synchronous DC/DC Converter

FEATURES

- 36V Input Voltage Surge
- Wide input voltage Range: 8V~30V
- Up to 3A Output Current
- 130kHz~500kHz Adjustable Frequency
- Internal Compensation
- 32V Input OVP Protection
- Output OVP Protection
- Efficiency up to 93%
- $\pm 2\%$ Feedback Voltage Accuracy
- Integrated Soft Start
- Thermal Shutdown
- Constant Current Limit
- Short Circuit Hiccup Mode
- Cycle-by-Cycle Current Limit
- SOP-8 Exposed Pad and DFN-8 (3x3) Packages

DESCRIPTION

AIC2933B is a wide input voltage, high efficiency step-down DC/DC converter that operates in force PWM mode with adjustable switching frequency. AIC2933B provides up to 3A output current. Switching frequency can be set by external resistor. AIC2933B internal Integrate 80m Ω high side and 60m Ω low side power MOSFET, which allows a high efficiency over the wider range of the load. Advanced production features include input UVLO, thermal shutdown, soft start and input and output OVP.

The AIC2933B requires a minimum number of readily available standard external components and is available in an 8-pin SOP-8 Exposed Pad and DFN-8 (3x3) packages.

APPLICATIONS

- Auto Electronic Equipment
- TV/Monitor
- Distributed Power Systems
- Networking Systems

APPLICATIONS CIRCUIT

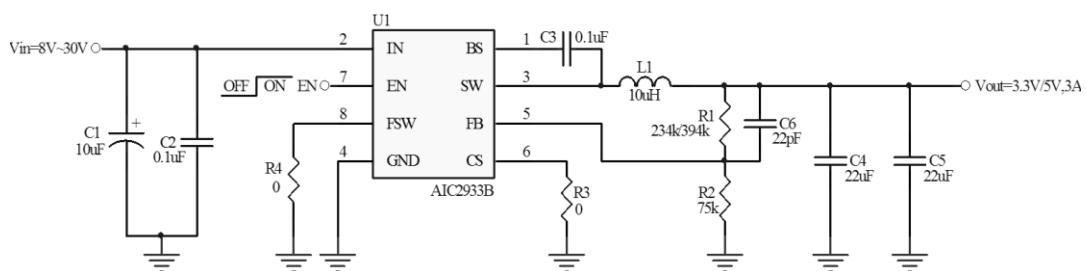

Fig. 1 Typical Application Circuit as DC/DC Converter

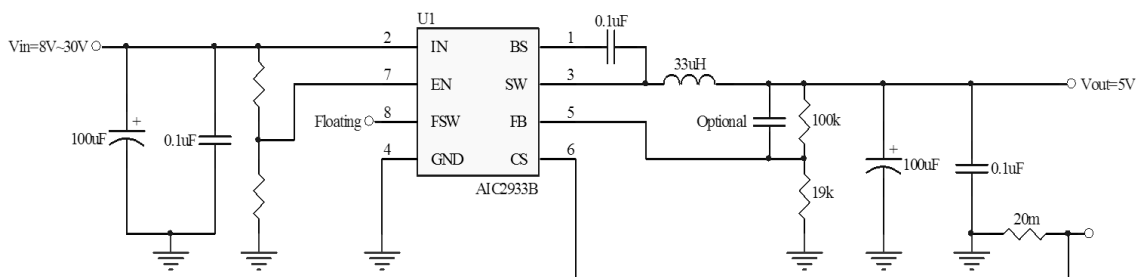
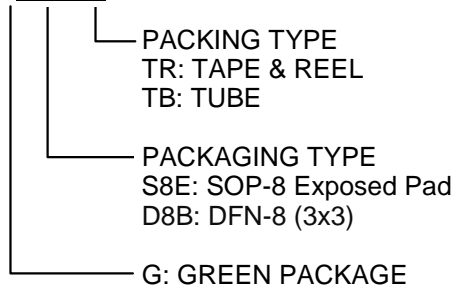

Fig. 2 Typical Application Circuit as Car Charger Converter with CC Function

ORDERING INFORMATION

AIC2933BXXXXXX



Example:

AIC2933BGS8ETR

→ Green SOP-8 Exposed Pad Package
and TAPE & REEL Packing Type

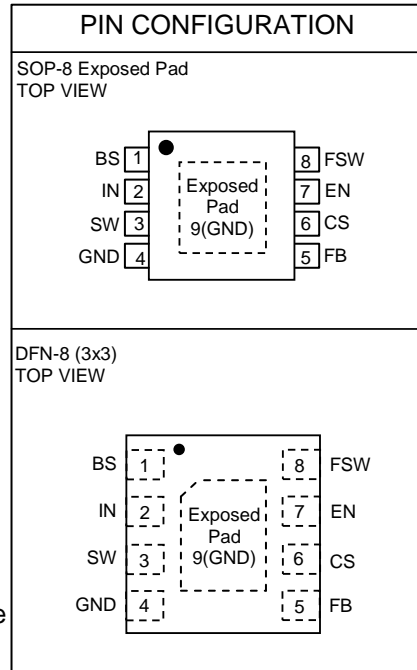

● Marking

Top Mark: T3331/YYXXX (T3331: Device Code, YYXXX: Inside Code)

Part No.	Marking
AIC2933BGS8E	T3331/YYXXX
AIC2933BGD8B	T3331/YYXXX

ABSOLUTE MAXIMUM RATINGS

IN Pin, SW Pin and EN Pin Voltage.....	-0.3V to 36V
BS to SW Voltage.....	-0.3V to 6V
Pin Voltage for all other Pins	-0.3V to 6V
Junction Temperature (Note 2)	-40°C to 150°C
Storage Temperature Range	-65°C to 150°C
Thermal Resistance Junction to Case	SOP-8 Exposed Pad..... 46°C/W
Thermal Resistance Junction to Ambient	SOP-8 Exposed Pad..... 60°C/W
	DFN-8 (3mmx3mm)
	60°C/W
Package Power Dissipation	SOP-8 Exposed Pad..... 2W
	DFN-8 (3mmx3mm)
	2W

(Assume no Ambient Airflow)

Absolute Maximum Ratings are those values beyond which the life of a device may be impaired.

ELECTRICAL CHARACTERISTICS
(V_{IN}=24V, V_{EN}=5V, T_A=25°C, unless otherwise specified.) (Note 1)

PARAMETER	SYMBOL	CONDITIONS	MIN	TYP	MAX	UNITS
Input Voltage Range	V _{IN}		8		30	V
Input Voltage Surge	V _{IN}				36	V
Under Voltage Lockout	V _{UVLO}	V _{IN} rising		7.2		V
UVLO Hysteresis	V _{UVLO_HY}			0.6		V
Quiescent Supply Current	I _{CCQ}	No Load, V _{FB} > 0.83V		1		mA
Standby Supply Current	I _{STBY}	V _{OUT} =5V, No Load		10	15	mA
Feedback Threshold Voltage	V _{FBTH}		784	800	816	mV
FB Pin Input Current	I _{FB}		-50		50	nA
Input OVP Voltage	V _{INOV}		31.5			V
Output OVP Voltage	V _{OUTOV}			10	20	%
Soft Start Time	T _{SST}			4		ms
CS Current Limit Voltage	V _{LIM_CS}			64		mV
SW Leakage	I _{SW_LEAK}				10	μA
Maximum Duty Cycle	D _{DUTY}	F _S =300kHz			90	%
Switching Frequency	F _S	R _{FSW} =300kΩ		310		kHz
		FSW pin floating		130		
		FSW pin short to GND		500		
Switch On-Resistance (H side)	R _{ON_HS}	By Design		80		mΩ
Switch On-Resistance (L side)	R _{ON_LS}	By Design		60		mΩ
Short Circuit Frequency	F _{SC}	V _{FB} =0V		35		kHz
Minimum Turn-on Time	T _{ON_MIN}			200		ns
EN High Level Input Voltage	V _{EN_H}		1.5			V
EN Low Level Input Voltage	V _{EN_L}				0.3	V
Thermal Shutdown Threshold <small>(Note 3)</small>	T _{SDN}			155		°C
Thermal Shutdown Hysteresis <small>(Note 3)</small>	T _{SDN_HY}			20		°C

Note 1: Specifications are production tested at T_A=25°C. Specifications over the -40°C to 85°C operating temperature range are assured by design, characterization and correlation with Statistical Quality Controls (SQC).

Note 2: T_J is calculated from the ambient temperature T_A and power dissipation P_D according to the following formula: T_J = T_A + P_D × θ_{JA}. The maximum allowable continuous power dissipation at any ambient temperature is calculated by P_{D(MAX)} = (T_{J(MAX)} - T_A) / θ_{JA}.

Note 3: Thermal shutdown threshold and hysteresis are guaranteed by design.

TYPICAL PERFORMANCE CHARACTERISTICS

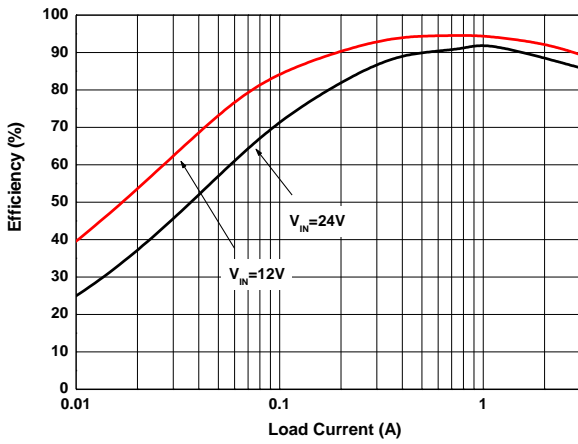

Fig. 3 Efficiency vs. Load Current ($V_{OUT}=5V$)

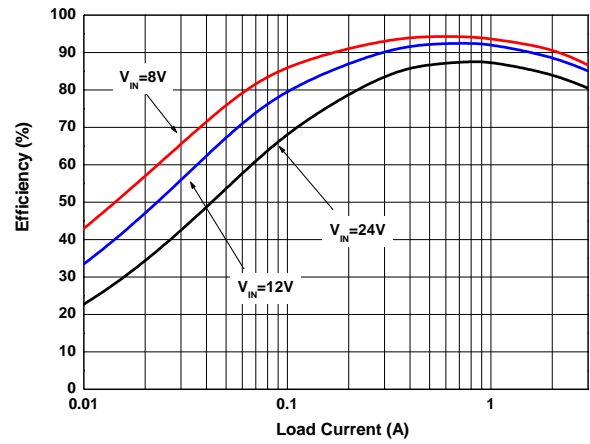

Fig. 4 Efficiency vs. Load Current ($V_{OUT}=3.3V$)

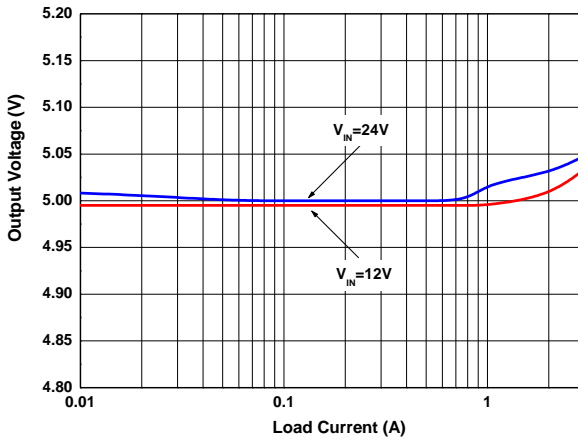

Fig. 5 Output Voltage vs. Load Current ($V_{OUT}=5V$)

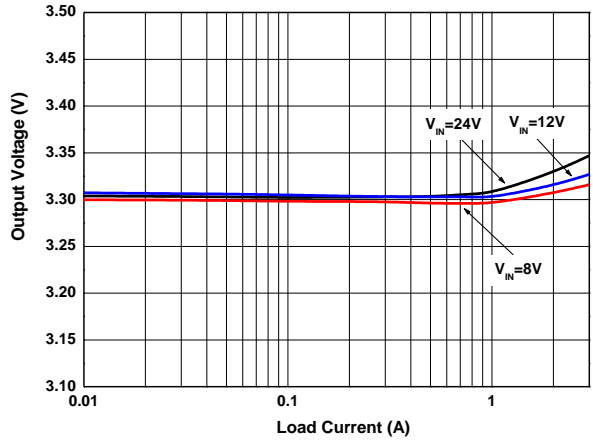

Fig. 6 Output Voltage vs. Load Current ($V_{OUT}=3.3V$)

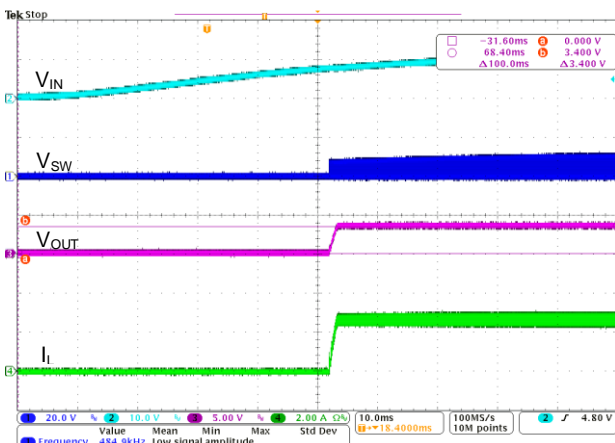

Fig. 7 V_{IN} Power On ($V_{IN}=12V$, $V_{OUT}=3.3V$, $I_{OUT}=3A$)

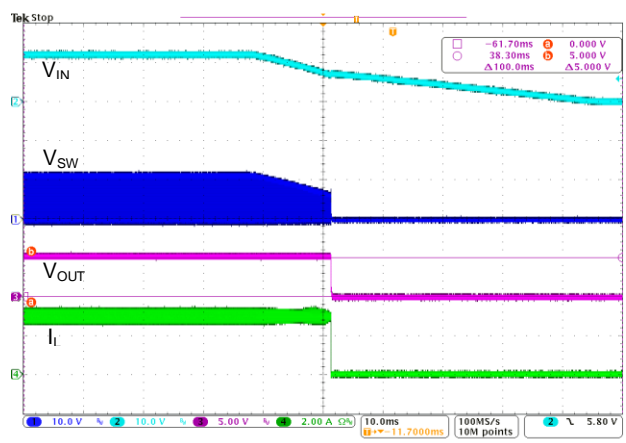
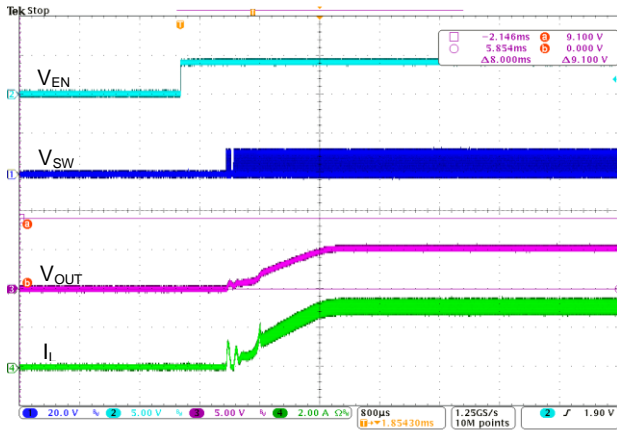
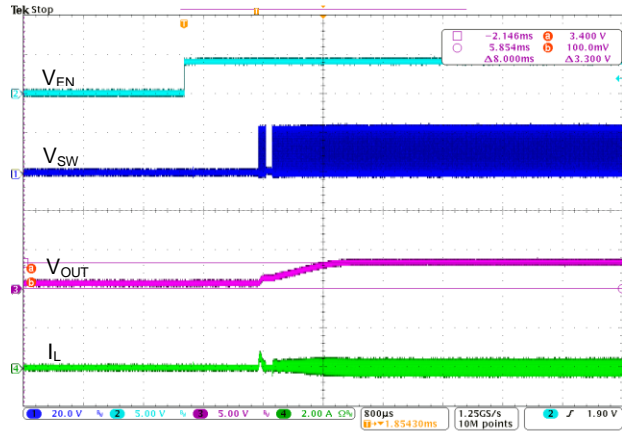
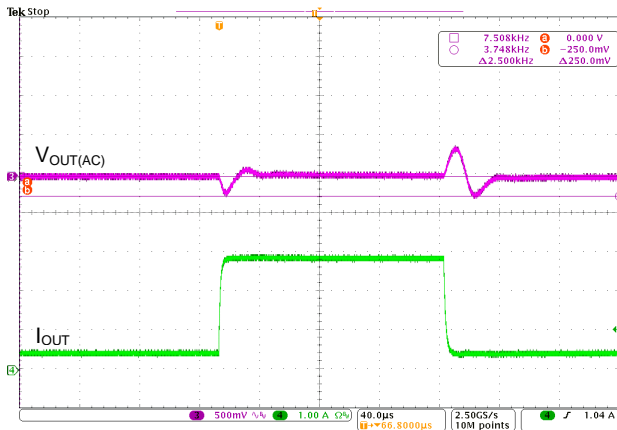
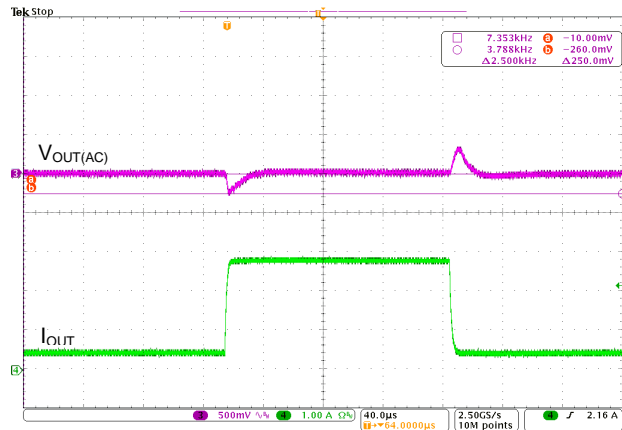
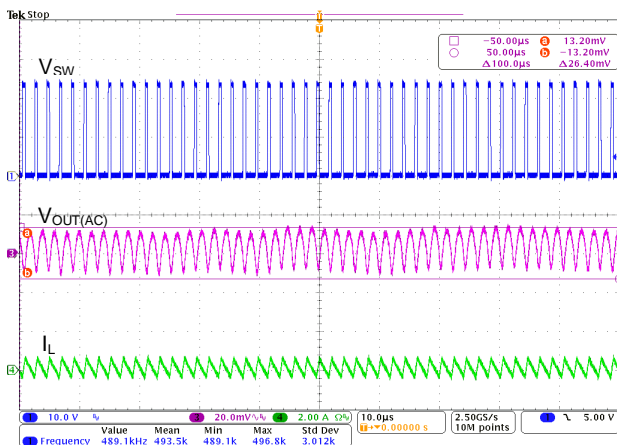
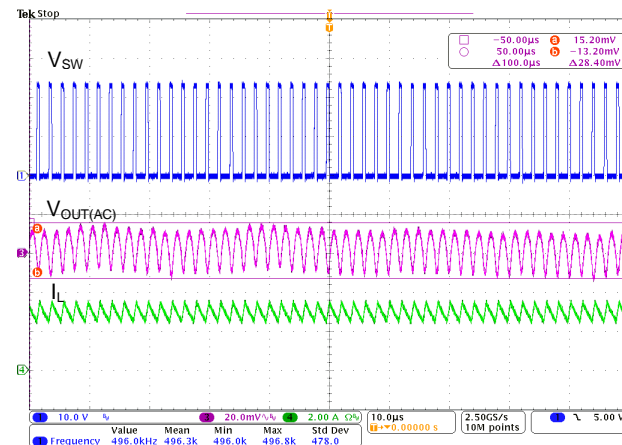
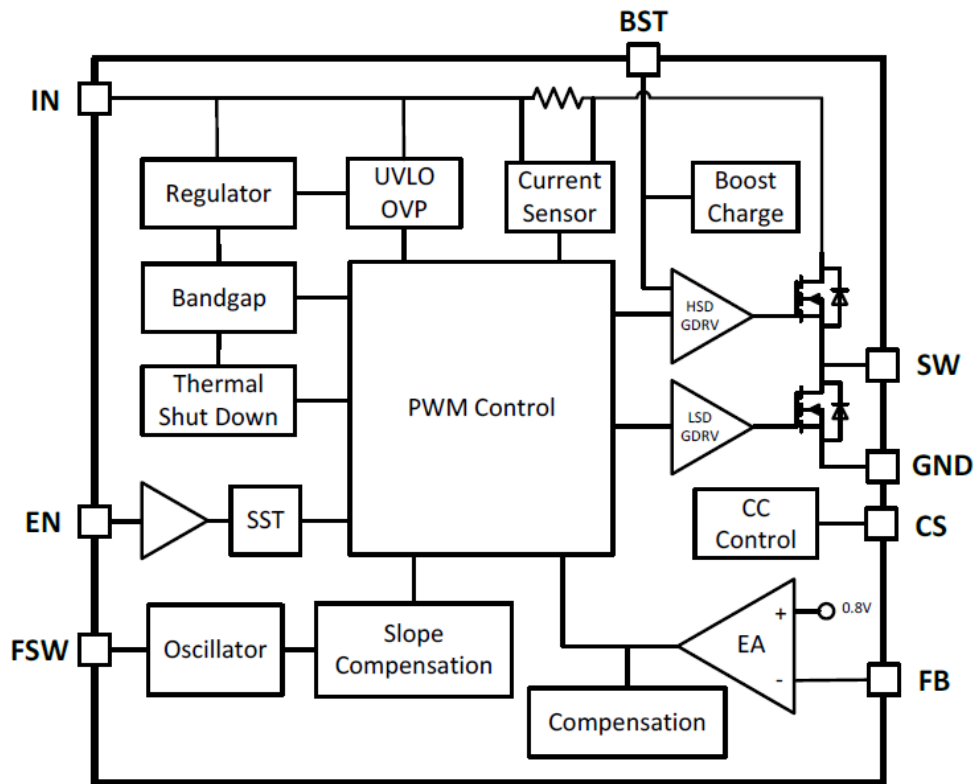

Fig. 8 V_{IN} Power Off ($V_{IN}=12V$, $V_{OUT}=5V$, $I_{OUT}=3A$)

TYPICAL PERFORMANCE CHARACTERISTICS (Continued)

 Fig. 9 Enable On ($V_{IN}=12V$, $V_{OUT}=5V$, $I_{OUT}=3A$)

 Fig. 10 Enable On ($V_{IN}=24V$, $V_{OUT}=3.3V$, $I_{OUT}=0A$)

 Fig. 11 Load Transient ($V_{IN}=12V$, $V_{OUT}=3.3V$, $I_O=0.3-2.7A$)

 Fig. 12 Load Transient ($V_{IN}=24V$, $V_{OUT}=5V$, $I_O=0.3-2.7A$)

 Fig. 13 Output Ripple ($V_{IN}=24V$, $V_{OUT}=5V$, $I_{OUT}=0.1A$)

 Fig. 14 Output Ripple ($V_{IN}=24V$, $V_{OUT}=5V$, $I_{OUT}=3A$)

■ BLOCK DIAGRAM

Functional Block Diagram
■ PIN DESCRIPTIONS

Pin No.	Pin Name	Pin Function
1	BS	High side Gate Driver bias pin. Provide supply to high-side LDMOS Gate Driver. Connect a 100nF capacitor between BS and SW.
2	IN	Power Input Pin.
3	SW	Switch Pin. Connect to External Inductor.
4	GND	Power Ground.
5	FB	Output Voltage Feedback Pin.
6	CS	Output Current Sense Pin for Constant Current Limit.
7	EN	Enable Pin.
8	FSW	Switching Frequency set pin. Short to GND: $F_s=500\text{kHz}$.
9	GND (Exposed Pad)	Ground (Exposed PAD).

APPLICATION INFORMATION

AIC2933B is a peak current mode pulse width modulation (PWM) converter with CC and CV control. The converter operates as follows: A switching cycle starts when the rising edge of the oscillator clock output causes the High-Side Power Switch to turn on and the Low-Side Power Switch to turn off. With the SW side of the inductor now connected to IN, the inductor current ramps up to store energy in the magnetic field. The inductor current level is measured by the Current Sense Amplifier and added to the Oscillator ramp signal. If the resulting summation is higher than the COMP voltage, the output of the PWM Comparator goes high. When this happens or when Oscillator clock output goes low, the High-Side Power Switch turns off.

At this point, the SW side of the inductor swings to a diode voltage below ground, causing the inductor current to decrease and magnetic energy to be transferred to output. This state continues until the cycle starts again. The High-Side Power Switch is driven by logic using BS as the positive rail. This pin is charged to VSW + 5V when the Low-Side Power Switch turns on. The COMP voltage is the integration of the error between FB input and the internal 0.8V reference. If FB is lower than the reference voltage, COMP tends to go higher to increase current to the output. Output current will increase and the output voltage be regulated.

Output Voltage Setting

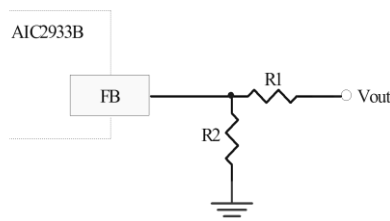

Fig. 15 Output Voltage Setting

Figure 15 shows the connections for setting the output voltage. Select the proper ratio of the two feedback resistors R_1 and R_2 based on the output voltage. Adding a capacitor in parallel with R_1 helps the system stability. Typically, use $R_2 \approx 75k\Omega$ and determine R_1 from the following equation:

$$R_1 = R_2 \times \left(\frac{V_{OUT}}{0.8V} - 1 \right)$$

For DC/DC application with only ceramic output capacitors (two paralleling $22\mu F$ capacitors or one $47\mu F$ capacitor are recommended), a $22pF$ feedforward capacitor paralleling with R_1 (R_1 is recommended larger than $200k\Omega$ resistance) is recommended for stability and better load transient performance.

Over Voltage Protection

The thresholds of input OVP circuit include are minimum $31.5V$. Once the input voltage is higher than the threshold, the high-side MOSFET is turned off. When the input voltage drops lower than the threshold, the high-side MOSFET will be enabled again.

Thermal Shutdown

The AIC2933B disables switching when its junction temperature exceeds $155^\circ C$ and resumes when the temperature has dropped by $20^\circ C$.

Setting the Switching Frequency

The oscillator normally switches at $130kHz \sim 500kHz$, which is set by FSW resistance as Table 1.

Table 1 Switching Frequency vs. R_{FSW}

R_{FSW}	Frequency (typ.)
Floating	130kHz
$R_{FSW}=300k\Omega$	310kHz
$R_{FSW}=250k\Omega$	350kHz
$R_{FSW}=200k\Omega$	410kHz
Short to GND	500kHz

Constant Current Limit Setting

A2933B has output constant current limit function. The constant current value is set by a resistor R_{CS} connected between the CS pin and GND. The CC output current is calculated by $I_{LIM}=64mV/R_{CS}$. If there is no constant current limit requirement, CS could be connected to GND directly and internal cycle-by-cycle peak current limit function is active with over current condition.

Setting the Cable Compensation

AIC2933B provides programmable cable voltage drop compensation using the impedance at the FB pin to compensate voltage drop across the charger's output cable if R_{CS} resistor is used between CS pin and GND. The cable compensation voltage can be expressed as: $V_{comp}=I_{load}\times 10^{-6}\times R_{FB1}$. By adjusting the value of R_{FB1} , the cable compensation voltage can be programmed.

EMI Consideration

Since parasitic inductance and capacitance effects in PCB circuitry would cause a spike voltage on SW node when high-side MOSFET is turned on/off, this spike voltage on SW may impact on EMI performance in the system. In order to enhance EMI performance, there are two methods to suppress the spike voltage. One is to place an RC snubber be-

tween SW and GND and make them as close as possible to the high-side MOSFET's source and low-side MOSFET's drain. Another method is to add a resistor in series with the bootstrap capacitor C_3 . But this method will decrease the driving capability to the high-side MOSFET. It is strongly recommended to reserve the RC snubber during PCB layout for EMI improvement. Moreover, reducing the PHASE trace area and keeping the main power in a small loop will be helpful on EMI performance.

PC Board Layout Guidance

When laying out the printed circuit board, the following checklist should be used to ensure proper operation of the IC.

1. Arrange the power components to reduce the AC loop size consisting of C_{IN} , IN pin, SW pin.
2. Place input decoupling ceramic capacitor C_{IN} as close to IN pin as possible. C_{IN} is connected power GND short and wide path or with vias.
3. Return FB to signal GND pin, and connect the signal GND to power GND at a single point for best noise immunity. Connect exposed pad to power ground copper area with copper and vias.
4. Use copper plane for power GND for best heat dissipation and noise immunity.
5. Place feedback resistor close to FB pin.
6. Use short trace connecting BS- C_{BS} -SW loop.

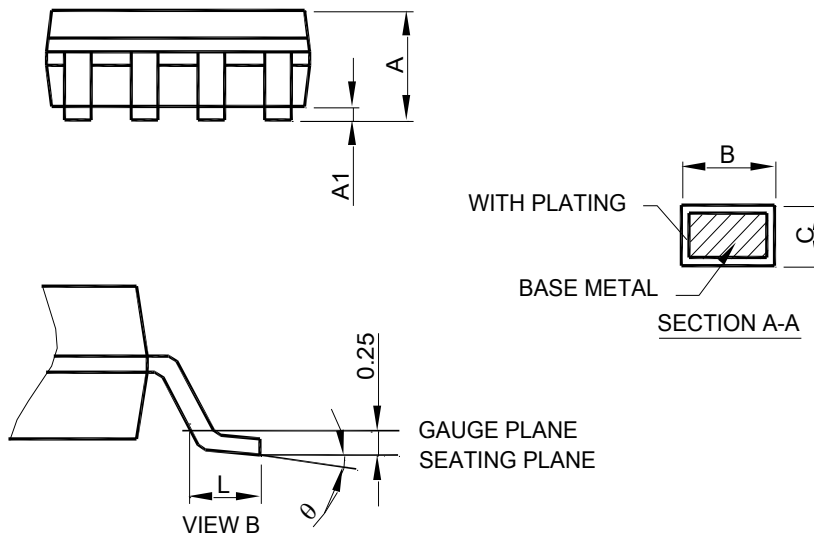
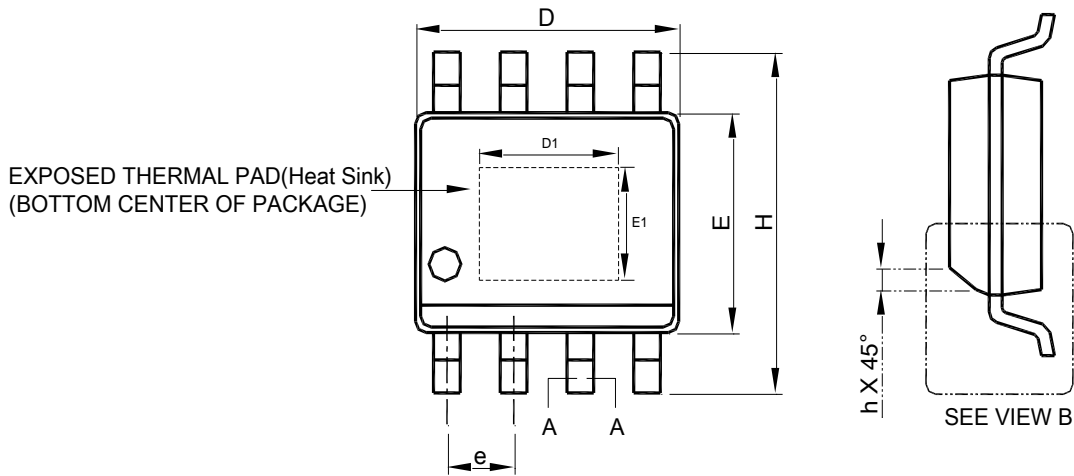
PHYSICAL DIMENSIONS
● SOP-8 Exposed Pad

- Note :
1. Refer to JEDEC MS-012E.
 2. Dimension "D" does not include mold flash, protrusions or gate burrs. Mold flash, protrusion or gate burrs shall not exceed 6 mil per side .
 3. Dimension "E" does not include inter-lead flash or protrusions.
 4. Controlling dimension is millimeter, converted inch dimensions are not necessarily exact.

SYMBOL	SOP-8 Exposed Pad	
	MILLIMETERS	
	MIN.	MAX.
A	1.35	1.75
A1	0.00	0.15
B	0.31	0.51
C	0.17	0.25
D	4.80	5.00
D1	1.50	3.50
E	3.80	4.00
E1	1.0	2.55
e	1.27 BSC	
H	5.80	6.20
h	0.25	0.50
L	0.40	1.27
θ	0°	8°

- DFN-8 (3x3x0.75-0.65mm)

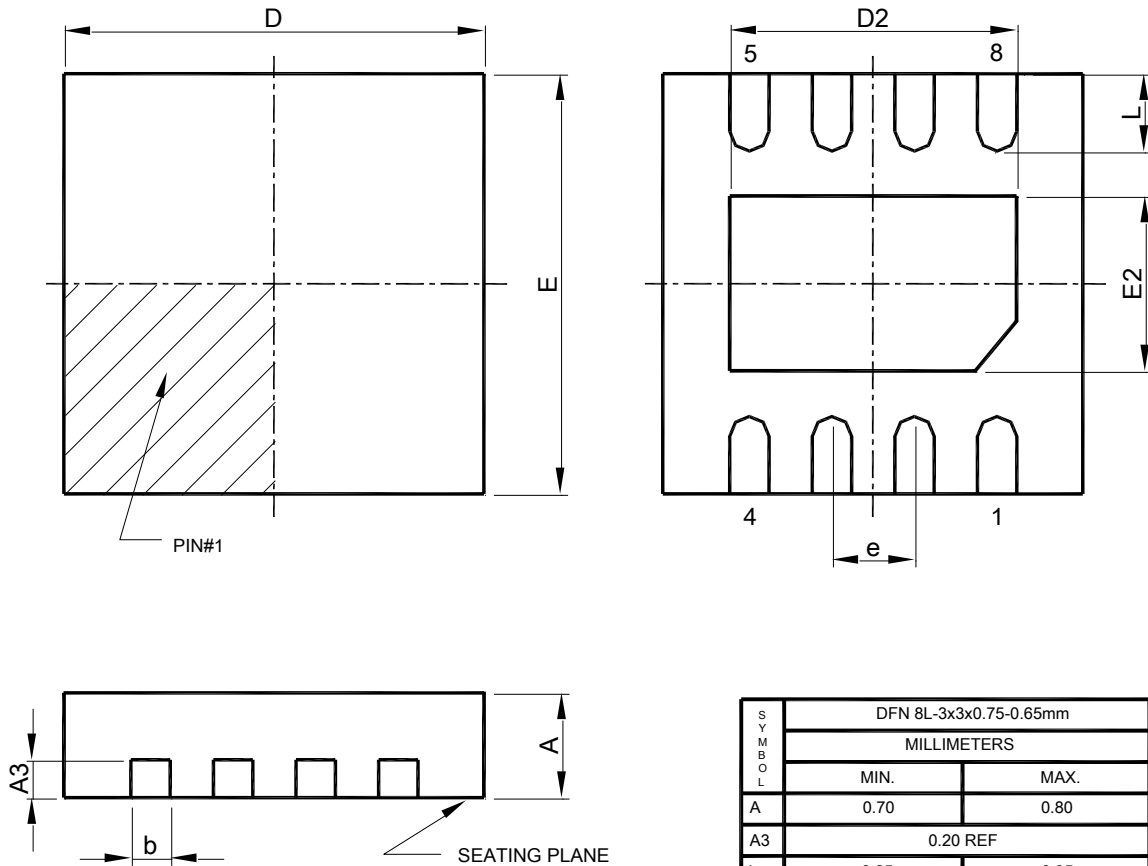

SYMBOL	DFN 8L-3x3x0.75-0.65mm	
	MILLIMETERS	
	MIN.	MAX.
A	0.70	0.80
A3	0.20 REF	
b	0.25	0.35
D	2.90	3.10
D2	2.20	2.40
E	2.90	3.10
E2	1.40	1.60
e	0.65 BSC	
L	0.25	0.45

Note : 1. Refer to JEDEC MO-220K.
 2. CONTROLLING DIMENSIONS : MILLIMETER , CONVERTED INCH DIMENSION ARE NOT NECESSARILY EXACT.

Note:

Information provided by AIC is believed to be accurate and reliable. However, we cannot assume responsibility for use of any circuitry other than circuitry entirely embodied in an AIC product; nor for any infringement of patents or other rights of third parties that may result from its use. We reserve the right to change the circuitry and specifications without notice.

Life Support Policy: AIC does not authorize any AIC product for use in life support devices and/or systems. Life support devices or systems are devices or systems which, (i) are intended for surgical implant into the body or (ii) support or sustain life, and whose failure to perform, when properly used in accordance with instructions for use provided in the labeling, can be reasonably expected to result in a significant injury to the user.