

800kHz, 18V, 2.0A AOT , Synchronous Step-Down Converter

In SOT563

FEATURES

- High Efficiency: Up to 93%(@3.3V)
- 800kHz Frequency Operation
- Up to 2.0A Output Current
- Low $R_{DS(ON)}$ for internal switches: 90m Ω /45m Ω (top/bottom)
- 4.5V to 18V Input Voltage Range
- 0.807V Reference
- AOT control to achieve fast transient responses
- Integrated internal compensation
- Stable with Low ESR Ceramic Output Capacitors
- Over Current Protection with Hiccup Mode
- Thermal Shutdown
- Inrush Current Limit and Soft Start
- Available in SOT563 Package

GENERAL DESCRIPTION

The AIC2847B is a high efficiency 800kHz AOT control mode synchronous step-down DC-DC converter capable of delivering 2A current. AIC2847B integrates main switch and synchronous switch with very low $R_{DS(ON)}$ to minimize the conduction loss. Low output voltage ripple and small external inductor and capacitor size are achieved with 800kHz switching frequency. It adopts the AOT architecture to achieve fast transient responses for high voltage step down applications.

The AIC2847B requires a minimum number of readily available standard external components and is available in a space saving 6-pin SOT563 ROHS compliant package.

APPLICATIONS

- Digital Set Top Boxes
- Flat Panel Television and Monitors
- Notebook computer
- Wireless and DSL Modems

TYPICAL APPILICATION

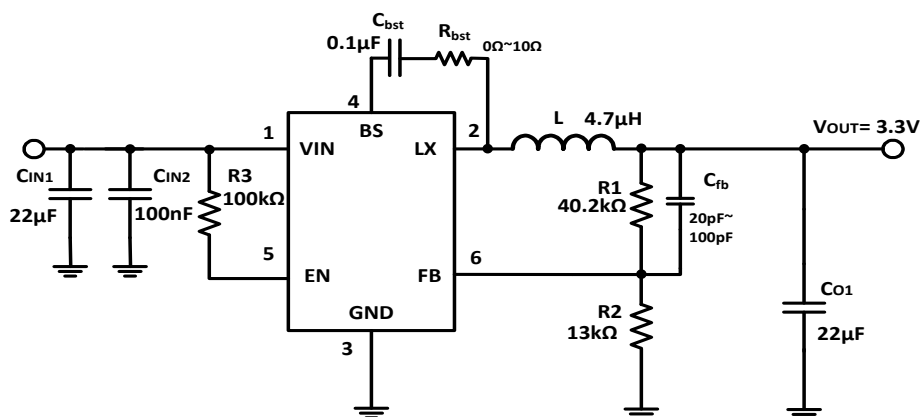

ABSOLUTE MAXIMUM RATINGS (Note 1)

Parameter	Min	Max	Unit
Input Supply Voltage, EN, LX	-0.3	20	V
LX Voltages(10ns transient)	-4	25	V
FB Voltage	-0.3	6	V
BS Voltage	VLX-0.3V	VLX+3V	V
Storage Temperature Range	-65	150	°C
Junction Temperature <small>(Note2)</small>	160		°C
Power Dissipation	600		mW
Lead Temperature (Soldering, 10s)	260		°C

PACKAGE/ORDER INFORMATION

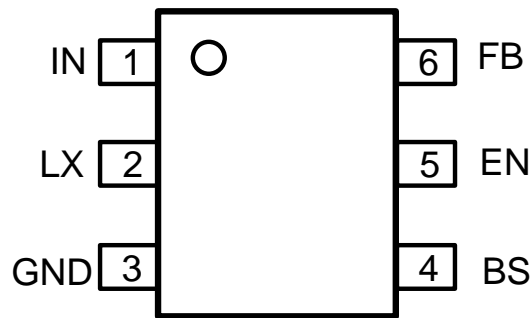

SOT563

Top Mark: TH2XXX (TH2: Device Code, XXX: Inside Code)

Part Number	Package
AIC2847B	SOT563

AIC2847B devices are Pb-free and RoHS compliant.

PIN FUNCTIONS

Pin	Name	Function
1	IN	Power Supply Pin
2	LX	Switching Pin
3	GND	Ground
4	BS	Bootstrap. A capacitor connected between LX and BST pins is required to form a floating supply across the high-side switch driver.
5	EN	Drive this pin to a logic-high to enable the IC. Drive to a logic-low to disable the IC and enter micro-power shutdown mode. Do not leave EN pin floating.
6	FB	Output Voltage feedback input. Connect FB to the center point of the external resistor divider.

ESD RATING

Items	Description	Value	Unit
ESD	Human Body Model for all pins	±2000	V

JEDEC specification JS-001

RECOMMENDED OPERATING CONDITIONS

Items	Description	Min	Max	Unit
Voltage Range	IN	4.5	18	V
T _J	Operating Temperature Range	-40	125	°C

THERMAL RESISTANCE_(Note3)

Items	Description	Value	Unit
θ _{JA}	Junction-to-ambient thermal resistance	130	°C/W

ELECTRICAL CHARACTERISTICS

$V_{IN}=12V$, $V_{OUT}=3.3V$, $T_A = 25^{\circ}C$, unless otherwise noted.

Parameter	Conditions	Min	Typ	Max	Unit
Input Voltage Range		4.5		18	V
OVP Threshold			19.3		V
UVLO Rising Threshold		4.0			V
UVLO Hysteresis			0.45		V
Quiescent Current	$V_{EN}=2.0V$, $I_{OUT}=0A$, $V_{FB}=V_{REF} \times 105\%$		300		μA
Shutdown Current	$V_{IN}=12V$, $EN=0V$		5	10	μA
Regulated Feedback Voltage	$T_A=25^{\circ}C$, $4.5V \leq V_{IN} \leq 18V$	0.791	0.807	0.823	V
High-Side Switch On-Resistance			90		m Ω
Low-Side Switch On-Resistance			45		m Ω
High-Side Switch Leakage Current	$V_{EN}=0V$, $V_{LX}=0V$	1		10	μA
Switch Valley Current Limit	Minimum Duty Cycle		3		A
On Time	$V_{IN}=12V$, $V_{OUT}=1.2V$, $I_{OUT}=1A$	100	125	160	ns
Oscillation Frequency			800		kHz
Maximum Duty Cycle	$V_{FB}=0.807V$		70		%
Minimum On-Time			80		ns
Soft Start Time			1		ms
Hiccup on Time			1.4		ms
Hiccup Time Before Restart			4		ms
EN Input High Level Voltage		1.2			V
EN Input Low Level Voltage				0.4	V
Thermal Shutdown Threshold <small>(Note 4)</small>			165		$^{\circ}C$
Thermal Shutdown Hysteresis <small>(Note 4)</small>			30		$^{\circ}C$

Note 1: Absolute Maximum Ratings are those values beyond which the life of a device may be impaired.

Note 2: T_J is calculated from the ambient temperature T_A and power dissipation P_D according to the following formula: $T_J = T_A + P_D \times \theta_{JA}$. The maximum allowable continuous power dissipation at any ambient temperature is calculated by $P_{D(MAX)} = (T_{J(MAX)} - T_A) / \theta_{JA}$.

Note 3: Measured on JESD51-7, 4-layer PCB.

Note 4: Thermal shutdown threshold and hysteresis are guaranteed by design.

BLOCK DIAGRAM

Figure 1. AIC2847B Block Diagram

OPERATION DESCRIPTION
Internal Regulator

The AIC2847B is a AOT step down DC/DC converter that provides excellent transient response with no extra external compensation components. This device contains low resistance, high voltage high side and low side power MOSFETs, and operates at 800kHz operating frequency to ensure a compact, high efficiency design with excellent AC and DC performance.

Error Amplifier

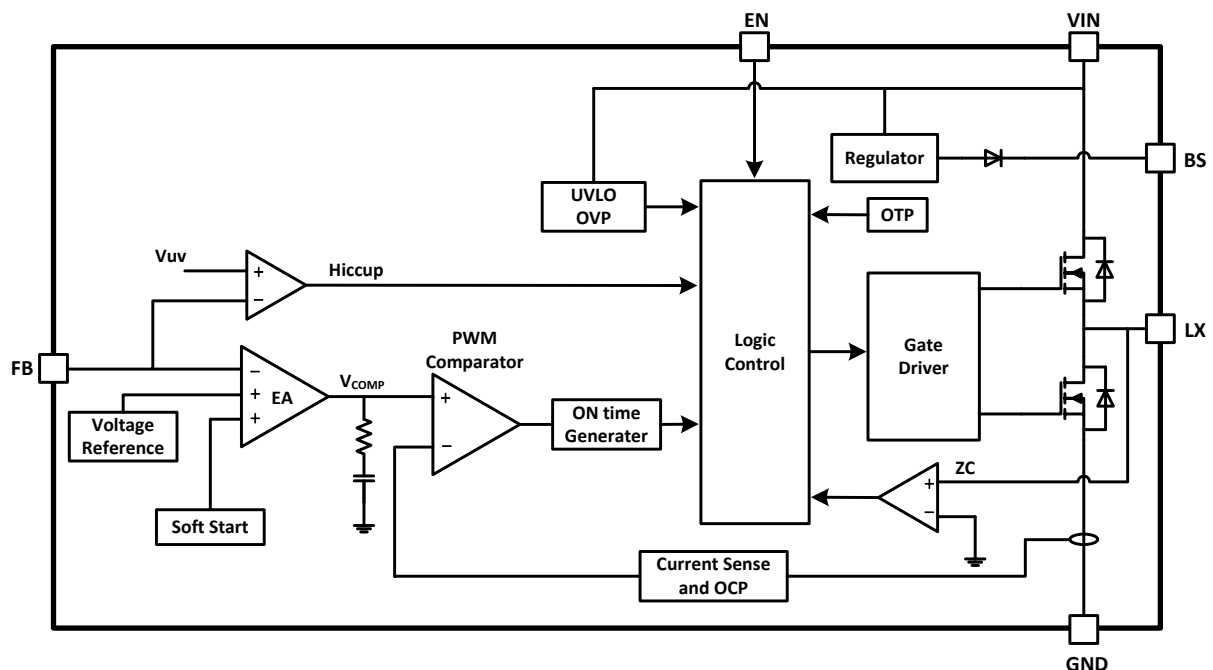
AIC2847B adopts operational transconductance amplifier as error amplifier. The error amplifier compares the FB pin voltage with the internal FB reference (V_{REF}) and outputs a current proportional to the difference between the two. This output current is then used to charge or discharge the internal compensation network to form the V_{COMP} voltage, which is used to compare with the low side power MOSFET current sensing signal and trigger on time pulse. The optimized internal compensation network minimizes the external component counts and simplifies the control loop design.

Internal Soft-Start

The soft-start is implemented to prevent the converter output voltage from overshooting during startup. When the chip starts, the internal circuitry generates a soft-start voltage (SS) ramping up from 0V to 0.807V. When it is lower than the internal FB reference (V_{REF}), SS overrides REF so the error amplifier uses SS as the reference. When SS is higher than V_{REF} , V_{REF} regains control. The SS time is internally fixed to 1ms typically.

Over-Current-Protection and Short Circuits Protection

The AIC2847B has cycle-by-cycle valley current limit function. When the inductor current valley value is larger than the valley current limit during low side MOSFET on state, the device enters into valley over current protection mode and low side MOSFET keeps on state until inductor current drops down to the value equal or lower than the valley current limit, and then on time pulse could be generated and high side MOSFET could turn on again.

If the output is short to GND and the output voltage drop until feedback voltage V_{FB} is below the output under-voltage V_{UV} threshold which is typically 35% of V_{REF} , AIC2847B enters into hiccup mode to periodically disable and restart switching operation. The hiccup mode helps to reduce power dissipation and thermal rise during output short condition. The period of AIC2847B hiccup mode is typically 5.4ms.

Startup and Shutdown

If both V_{IN} and EN are higher than their appropriate thresholds, the chip starts switching operation. The reference block starts first, generating stable reference voltage and currents, and then the internal regulator is enabled. The regulator provides stable supply for the remaining circuitries. Three events can shut down the chip: EN low, V_{IN} low and thermal shutdown. In the shutdown procedure, the signaling path is first blocked to avoid any fault triggering. The V_{COMP} voltage and the internal supply rail are then pulled down. The floating driver is not subject to this shutdown command.

APPLICATION INFORMATION

Setting the Output Voltage

The external resistor divider is used to set the output voltage (see Typical Application on page 1). Choose R_1 to be around 40k Ω for optimal transient response. R_2 is then given by:

Table 1: Selection for Common Output Voltages

V_{OUT} (V)	R_1 (k Ω)	R_2 (k Ω)	C_{FB} (pF)	L (μ H)
5	40.2	7.68	33	4.7
3.3	40.2	13	33	4.7
2.5	40.2	19.1	33	3.3
1.8	40.2	32.4	33	2.2
1.5	40.2	45.3	33	2.2
1.2	40.2	82	33	1.5
1	20.5	84.5	33	1.0

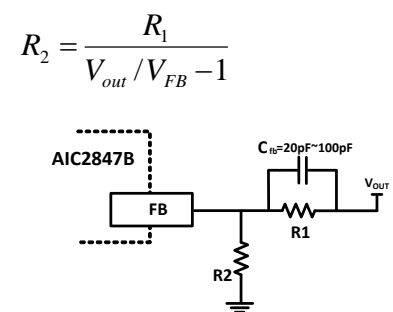

Figure 2. Feedback Network

Selecting the Inductor

A DC current rating of at least 25% percent higher than the maximum load current is recommended for most applications. Inductance value is related to inductor ripple current value, input voltage, output voltage setting and switching frequency. The inductor value can be derived from the following equation:

$$L = \frac{V_{OUT} \times (V_{IN} - V_{OUT})}{V_{IN} \times \Delta I_L \times f_{OSC}}$$

Where ΔI_L is inductor ripple current. Large value inductors result in lower ripple current and small value inductors result in high ripple current, so inductor value has effect on output voltage ripple value. DC resistance of inductor which has impact on efficiency of DC/DC converter should be taken into account when selecting the inductor. The maximum inductor peak current is:

$$I_{L(MAX)} = I_{LOAD} + \frac{\Delta I_L}{2}$$

Under light load conditions, larger inductance is recommended for improved light load efficiency.

Selecting the Output Capacitor

The output capacitor (Co1) is required to maintain the DC output voltage. Ceramic, tantalum, or low ESR electrolytic capacitors are recommended. Low ESR capacitors are preferred to keep the output voltage ripple low. The output voltage ripple can be estimated by:

$$\Delta V_{OUT} = \frac{V_{OUT}}{f_s \times L} \times \left[1 - \frac{V_{OUT}}{V_{IN}} \right] \times \left[R_{ESR} + \frac{1}{8 \times f_s \times C_2} \right]$$

Where L is the inductor value and R_{ESR} is the equivalent series resistance (ESR) value of the output capacitor. In the case of ceramic capacitors, the impedance at the switching frequency is dominated by the capacitance. The output voltage ripple is mainly caused by the capacitance. For simplification, the output voltage ripple can be estimated by:

$$\Delta V_{OUT} = \frac{V_{OUT}}{8 \times f_s^2 \times L \times C_2} \times \left[1 - \frac{V_{OUT}}{V_{IN}} \right]$$

In the case of tantalum or electrolytic capacitors, the ESR dominates the impedance at the switching frequency. For simplification, the output ripple can be approximated to:

$$\Delta V_{OUT} = \frac{V_{OUT}}{f_s \times L} \times \left[1 - \frac{V_{OUT}}{V_{IN}} \right] \times R_{ESR}$$

The characteristics of the output capacitor also affect the stability of the regulation system. The AIC2847B can be optimized for a wide range of capacitance and ESR values.

PCB Layout Guide

PCB layout is very important to achieve stable operation. It is highly recommended to duplicate EVB layout for optimum performance. If change is necessary, please follow these guidelines and take Figure 3 for reference.

- 1) Keep the path of switching current short and minimize the loop area formed by Input capacitor, IN pin and GND.
- 2) Bypass ceramic capacitors are suggested to be put close to the IN Pin.
- 3) Ensure all feedback connections are short and direct. Place the feedback resistors as close to the chip as possible.
- 4) VOUT, LX away from sensitive analog areas such as FB.
- 5) Connect IN, LX, and especially GND respectively to a large copper area to cool the chip to improve thermal performance and long-term reliability.

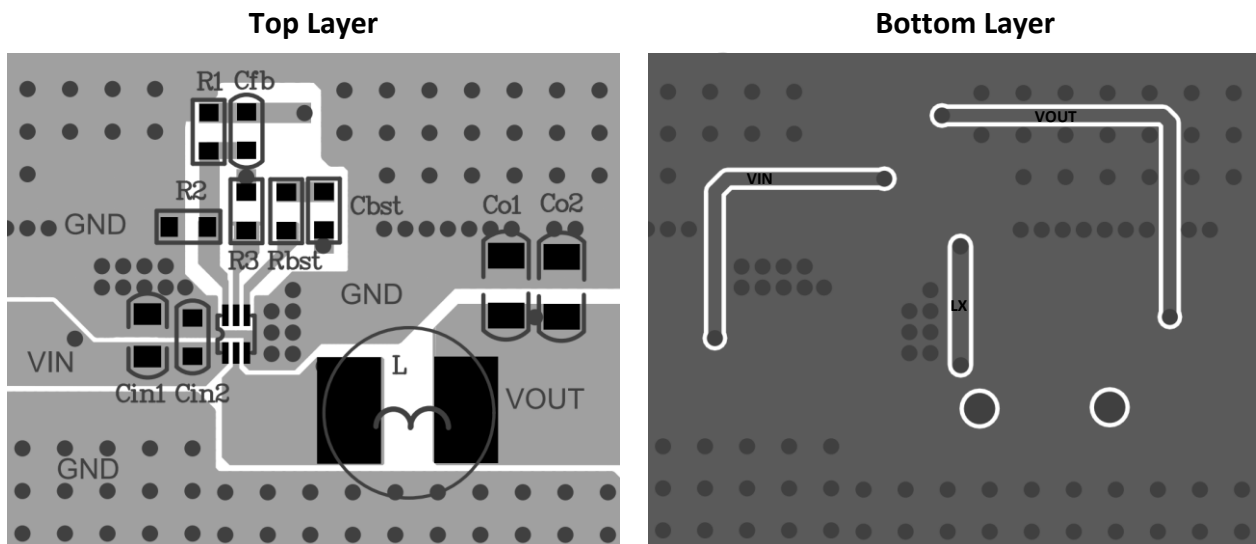
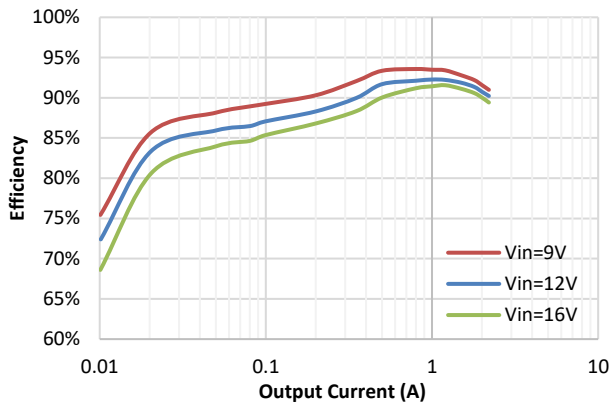

Figure 3. Sample of PCB Layout

TYPICAL PERFORMANCE CHARACTERISTICS

Efficiency at $V_{OUT} = 3.3V$

$V_{OUT} = 3.3V$, $L = 4.7\mu H$, $DCR = 30m\Omega$



Efficiency at $V_{OUT} = 5V$

$V_{OUT} = 5V$, $L = 4.7\mu H$, $DCR = 30m\Omega$

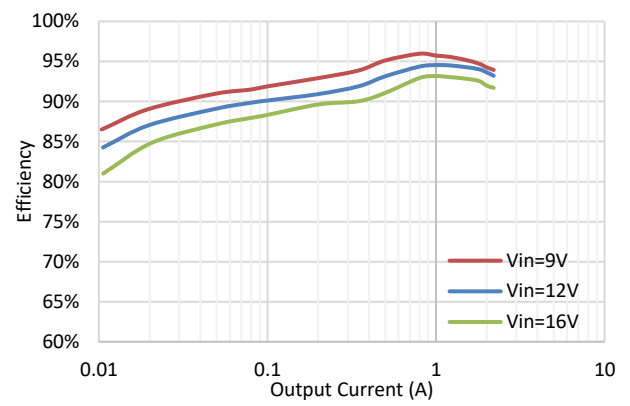

Efficiency at $V_{OUT} = 1.2V$

$V_{OUT} = 1.2V$, $L = 2.2\mu H$, $DCR = 20m\Omega$

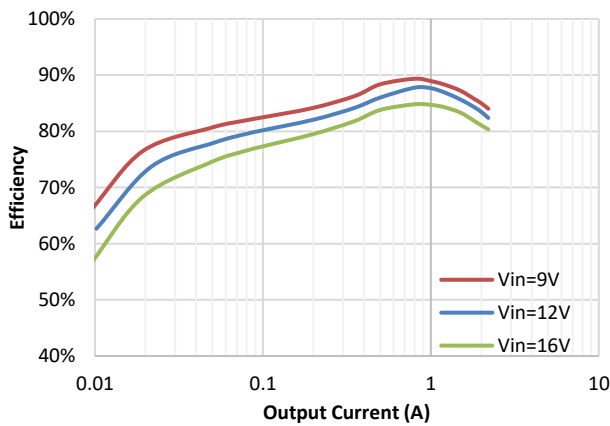

Load Regulation at $V_{IN} = 12V$

$V_{IN} = 12V$, $T_A = 25^\circ C$

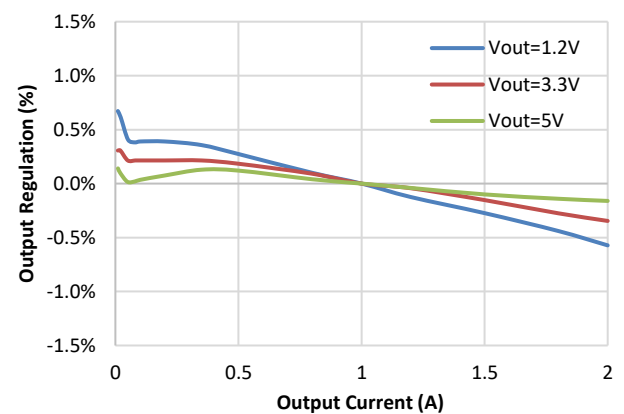

Steady State Operation

$V_{IN} = 12V$, $V_{OUT} = 3.3V$, No Load

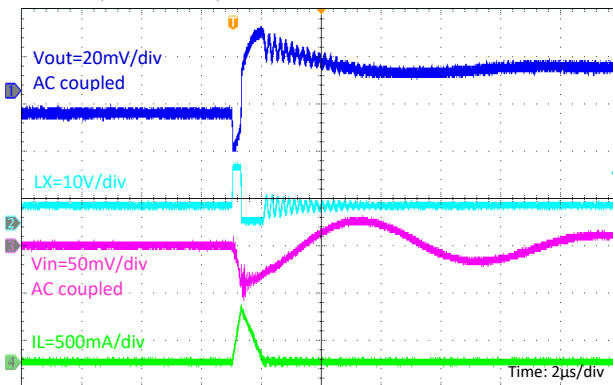

Steady State Operation

$V_{IN} = 12V$, $V_{OUT} = 3.3V$, $I_o = 2A$

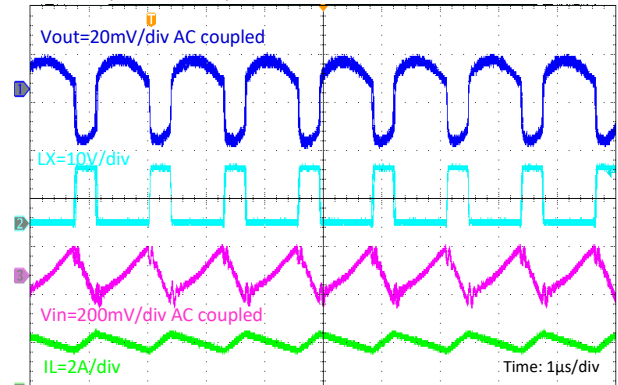

TYPICAL PERFORMANCE CHARACTERISTICS (continued)

Load Transient

$V_{IN} = 12V$, $V_{OUT} = 3.3V$, $I_o = 0A$ to $2A$

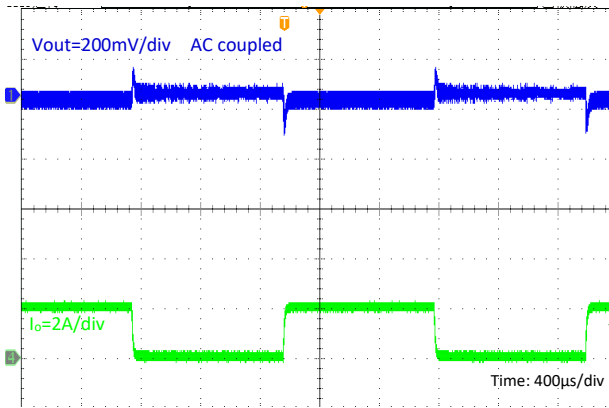

Load Transient

$V_{IN} = 12V$, $V_{OUT} = 3.3V$, $I_o = 1A$ to $2A$

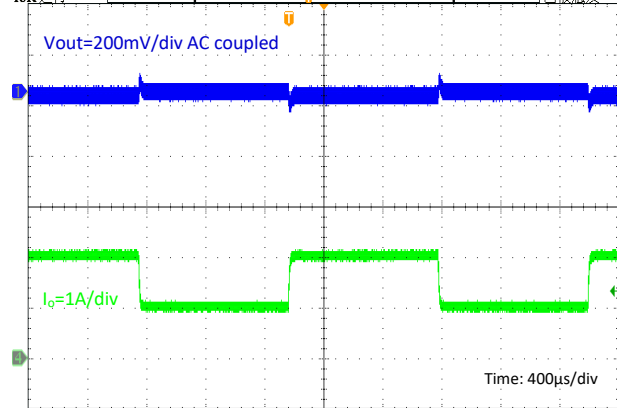

Output Short Entry

$V_{IN} = 12V$, $V_{OUT} = 3.3V$, No Load

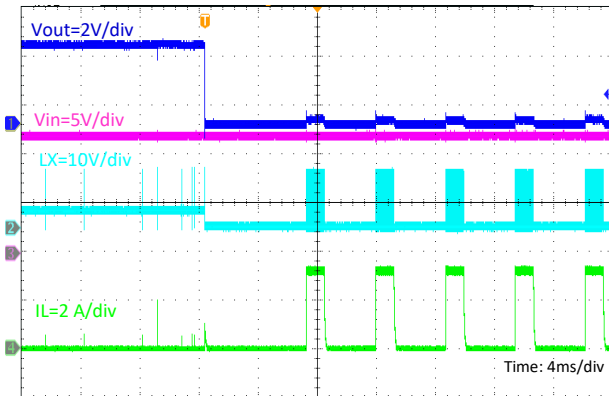

Output Short Recovery

$V_{IN} = 12V$, $V_{OUT} = 3.3V$, No Load

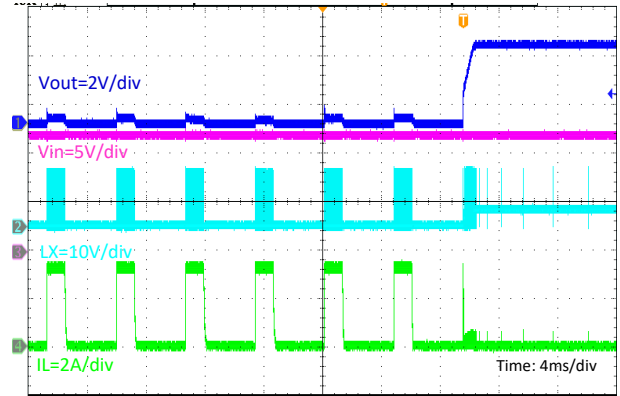

Input Power On

$V_{IN} = 12V$, $V_{OUT} = 3.3V$, $I_o = 2A$

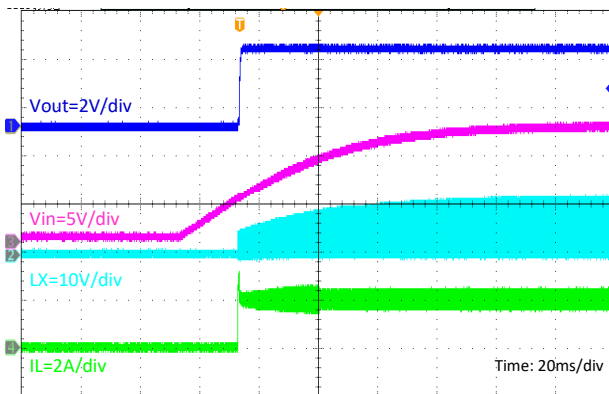

Input Power Down

$V_{IN} = 12V$, $V_{OUT} = 3.3V$, $I_o = 2A$

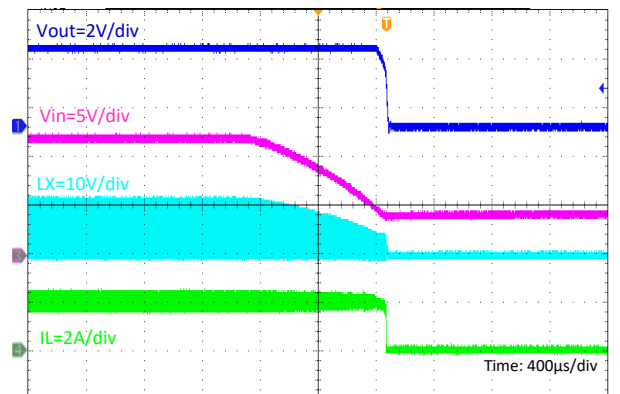

TYPICAL PERFORMANCE CHARACTERISTICS (continued)

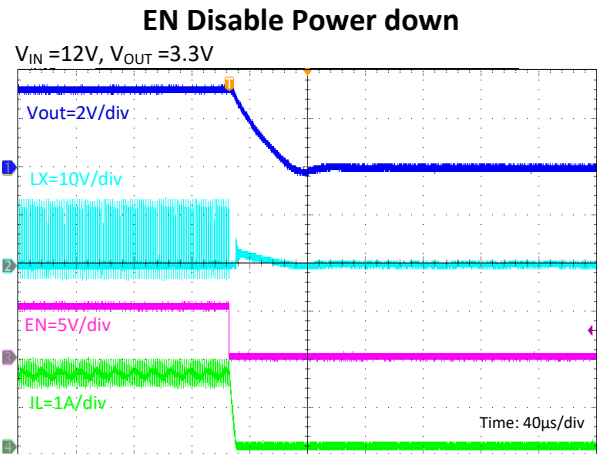
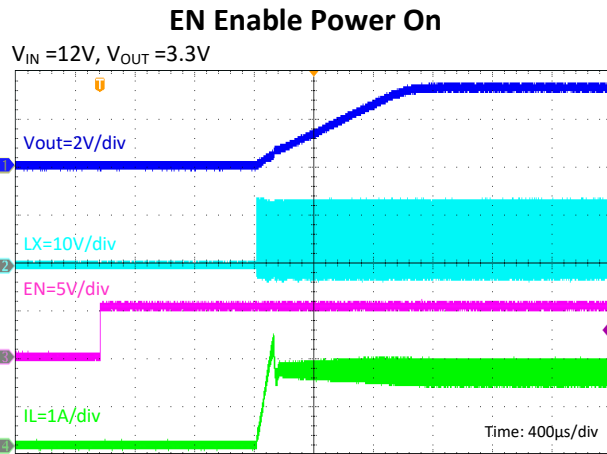

TYPICAL APPLICATION CIRCUITS

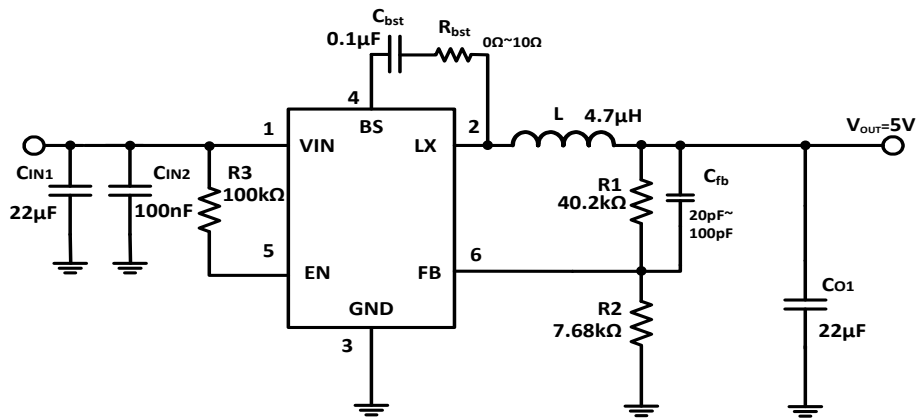

Figure 4. 12V_{IN}, 5V/2A Output

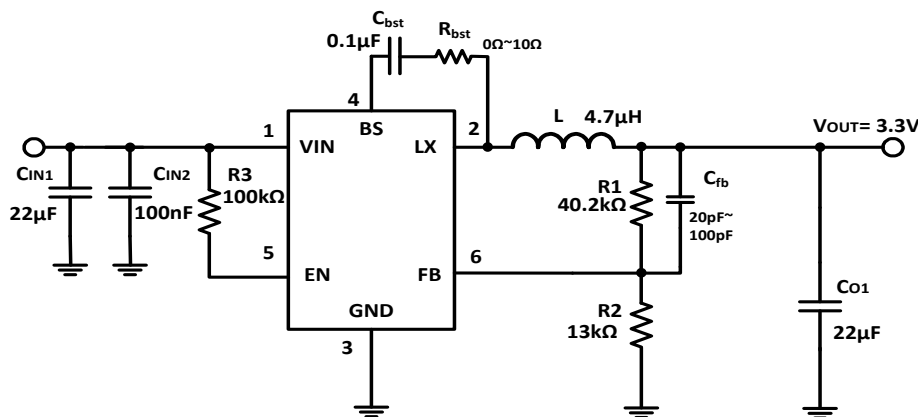

Figure 5. 12V_{IN}, 3.3V/2A Output

TYPICAL APPLICATION CIRCUITS (continued)

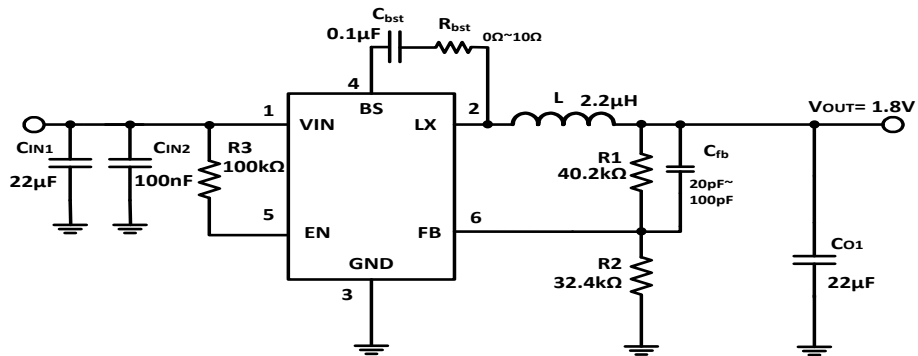

Figure 6. 12V_{IN}, 1.8V/2A Output

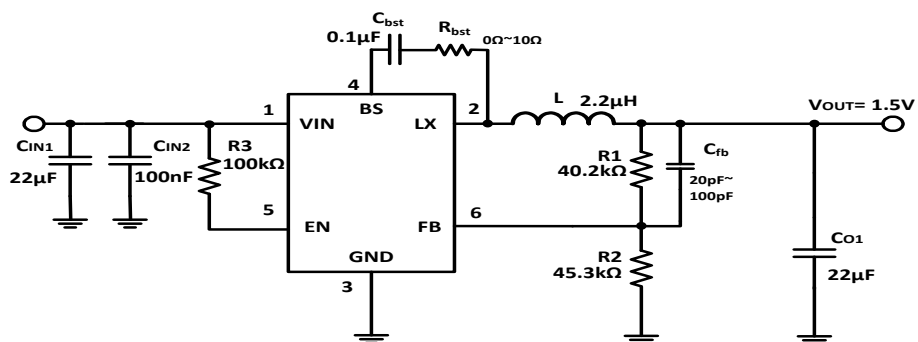

Figure 7. 12V_{IN}, 1.5V/2A Output

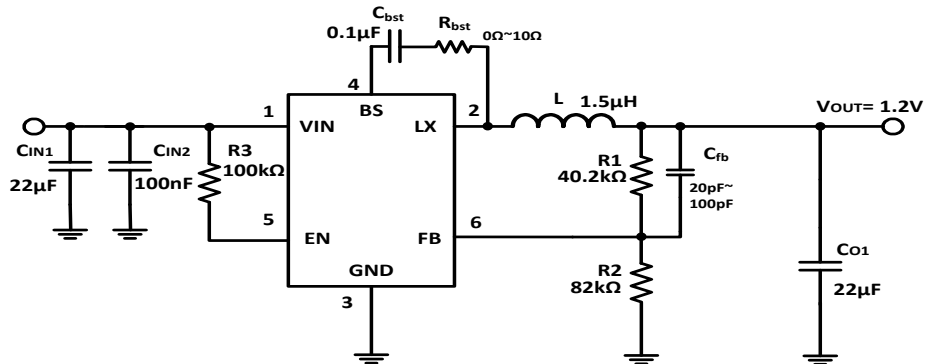

Figure 8. 12V_{IN}, 1.2V/2A Output

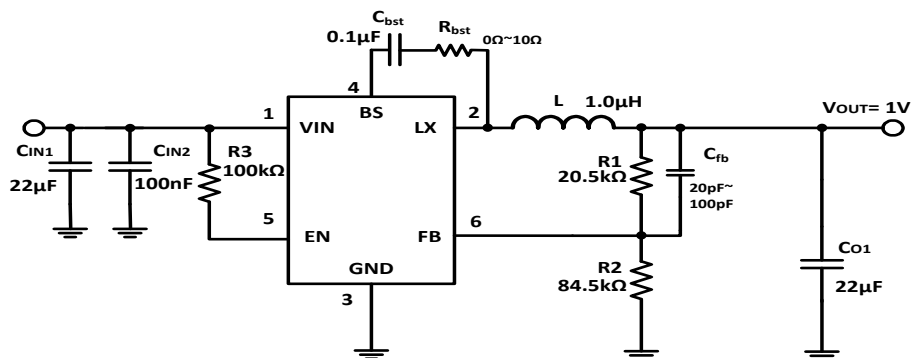
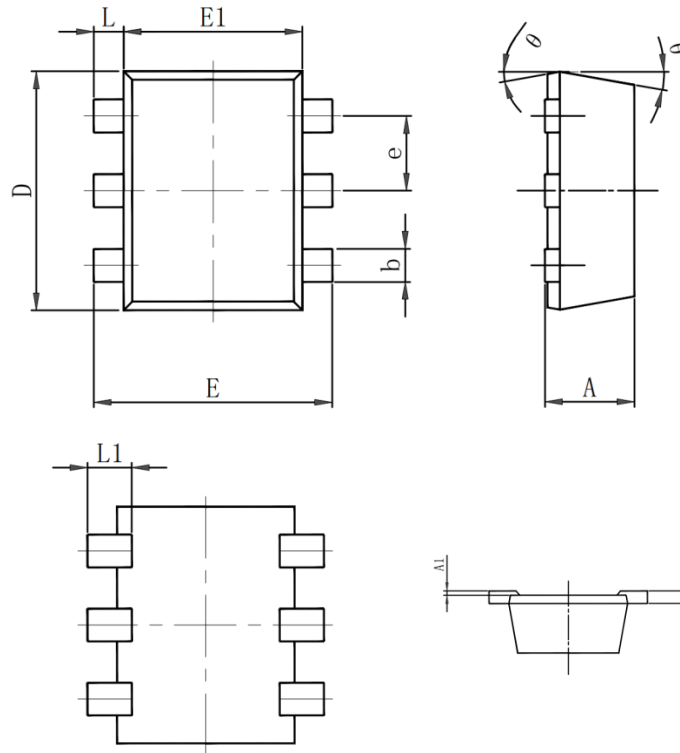

Figure 9. 12V_{IN}, 1V/2A Output

PACKAGE INFORMATION

SOT563



Symbol	Dimensions In Millimeters		Dimensions In Inches	
	Min.	Max.	Min.	Max.
A	0.525	0.600	0.021	0.024
A1	0.000	0.050	0.000	0.002
e	0.450	0.550	0.018	0.022
c	0.090	0.180	0.004	0.007
D	1.500	1.700	0.059	0.067
b	0.170	0.270	0.007	0.011
E1	1.100	1.300	0.043	0.051
E	1.500	1.700	0.059	0.067
L	0.100	0.300	0.004	0.012
L1	0.200	0.400	0.008	0.016
θ	9° REF.		9° REF.	

Note:

- 1) All dimensions are in millimeters.
- 2) Package length does not include mold flash, protrusion or gate burr.
- 3) Package width does not include interlead flash or protrusion.
- 4) Lead popularity (bottom of leads after forming) shall be 0.10 millimeters max.
- 5) Pin 1 is lower left pin when reading top mark from left to right.